

ESPC3-05

—2.4GHz Wi-Fi and BLE5.0 Combo Module

Version: 2.0

Date: Jan.5, 2024

Product Specification

Features

■ General

- Chip: ESP32-C3FH4
- Module Size: 16mm*20mm*3mm
- 32Mbit embedded flash
- 384KB ROM
- 400KB SRAM

■ Wi-Fi Features

- IEEE 802.11 b/g/n-compliant
- Center frequency range of operating channel: 2412 ~ 2484 MHz
- Supports 20 MHz, 40 MHz bandwidth in 2.4 GHz band
- 1T1R mode with data rate up to 150 Mbps
- TX/RX A-MPDU, TX/RX A-MSDU
- Immediate Block ACK
- Fragmentation and defragmentation
- Automatic Beacon monitoring (hardware TSF)
- 4 X virtual Wi-Fi interfaces
- Simultaneous support for Infrastructure BSS in Station mode, Soft-AP mode, Station + Soft-AP mode, and promiscuous mode

■ Bluetooth Features

- Bluetooth LE: Bluetooth 5, Bluetooth mesh
- Speed: 125 Kbps, 500 Kbps, 1 Mbps, 2 Mbps
- Advertising extensions
- Multiple advertisement sets
- Channel selection algorithm #2

■ Peripheral Interfaces

- GPIO * 15;

- UART * 2;
- IIC ;
- SPI;
- EN ;
- PWM x 6 ;
- ADC;

■ Working Temperature: -40°C -105°C

Applications

- Serial transparent transmission;
- Wi-Fi prober;
- Smart power plug/Smart LED light;
- Mesh networks;
- Sensor networks;
- Over-the-top (OTT) devices;
- Wireless location system beacon;
- Industrial field bus;

Module Type

Name	Flash	Antenna
ESPC3-05	32M bit	PCB

Module Structure

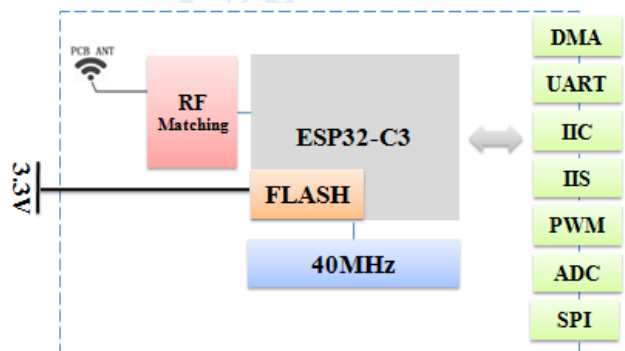

Update Record

Date	Version	Update
2023-02-20	V1.0	First released
2024-01-05	V2.0	Change C3FN4 to C3FH4, Add GPIO8

Table of Contents

1. Introduction	1
2. Interface Definition	3
3. Size and Layout	5
4. Electronica Characteristics	6
5. Power Consumption	7
6. Wi-Fi RF Characteristics.....	7
7. Bluetooth LE Radio.....	9
8. Recommended Sold Temperature Curve	11
9. Minimum User System.....	11
10. Recommended Layout Design	12
11. Peripheral Design Suggestion	13
12. Product Handling.....	14
13. Packing Instruction.....	14
14. Module Schematic	15

1. Introduction

ESPC3-05 Wi-Fi and BLE coexistence Module is a highly integrated single-chip low power 802.11bgn Wireless LAN (WLAN) network controller. It combines a RISC CPU, WLAN MAC, a 1T1R capable WLAN baseband, RF, and Bluetooth in a single chip. It also provides a bunch of configurable GPIO, which are configured as digital peripherals for different applications and control usage.

ESPC3-05 Module use ESP32-C3FH4 as Wi-Fi and BLE coexistence SOC chip.

ESPC3-05 Module integrates internal memories for complete Wi-Fi protocol functions. The embedded memory configuration also provides convenient application developments.

ESPC3-05 module supports the standard IEEE802.11 b/g/n/e/i protocol and the complete TCP/IP protocol stack. User can use it to add the Wi-Fi function for the installed devices, and also can be viewed as an independent network controller. Anyway, ESPC3-05 Wi-Fi module provides many probabilities with the best price.

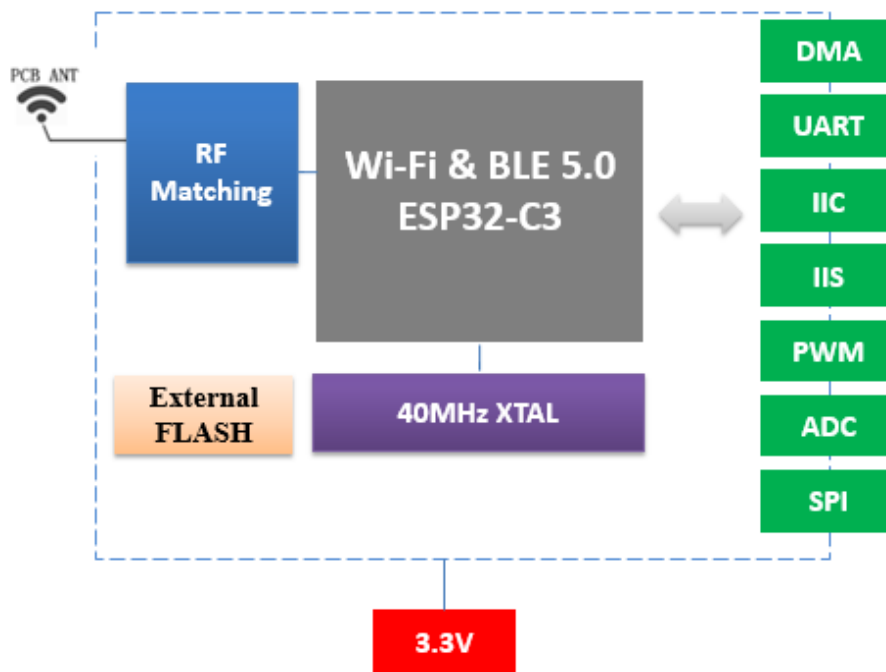

Fig.1.1 ESPC3-05 Module Structure

Technical parameters for ESPC3-05 are listed as follows.

Table.1.1 ESPC3-05 Parameters

Type	Item	Parameter
Wi-Fi	Frequency	2.4G~2.5G (2412M~2484M)
	Transmit power	802.11b: +20.5 dBm
		802.11g: +19 dBm
		802.11n: +17.5 dBm
	Receiver sensitivity	802.11b: -89 dBm (11Mbps)
		802.11g: -77 dBm (54Mbps)
		802.11n: -74 dBm (MCS7)
	EVM	-25dB @802.11b,11Mbps @21dBm
-28dB @802.11n,54Mbps @19dBm		
-30dB @802.11n,HT40,MCS7 @18.5dBm		
Antenna	PCB antenna / U.FL	
BLE	RF power control range	-27~18dBm
Hardware	CPU	32-bit RISC CPU
	Interface	UART/SDIO/SPI/I2C/GPIO/PWM
	Working voltage	3.0V ~ 3.6V
	Working temperature	-40°C ~ 105°C
	Environment temperature	-40°C ~ 105°C
	Shape	16mm x 20mm x 3mm
Software	Wi-Fi working mode	STA, Soft-AP and sniffer modes
	Security mode	WPS / WEP / WPA / WPA2 / WPA3
	Update firmware	UART Download
	Software develop	SDK
	Network protocol	IPv4, TCP/UDP/HTTP/FTP/MQTT

2. Interface Definition

ESPC3-05 Wi-Fi & BLE module interface definition is shown as below.

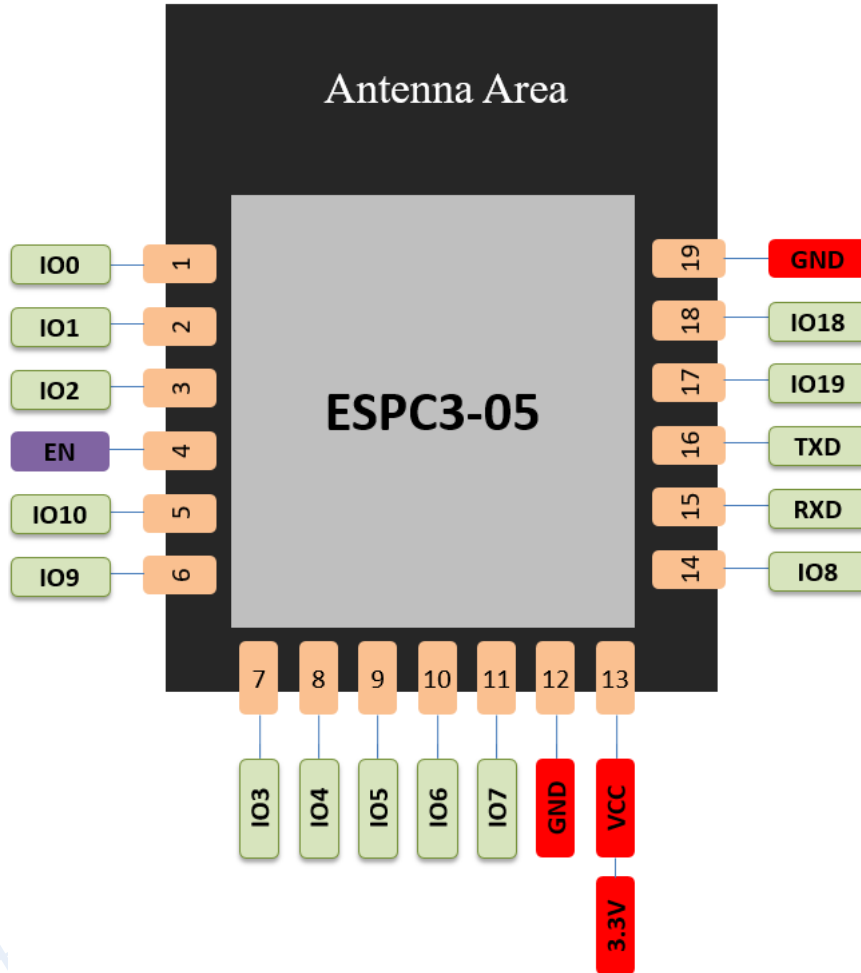

Fig.2.1 ESPC3-05 Pins Definition

Working modes and pins function is shown in Table 2.1.

Table.2.1 Working Mode

Mode	IO9 Voltage Level
UART Download Mode	LOW
Flash Boot Mode	HIGH (Default)

Table.2.2 Pins Function Definition

Num.	Pin Name	Type	Function
1	IO0	I/O	GPIO0, ADC1_CH0, XTAL_32K_P
2	IO1	I/O	GPIO1, ADC1_CH1, XTAL_32K_N

3	IO2	I/O	GPIO2,ADC1_CH2,FSPIQ
4	EN	I/O	Chip enable; Internal Pull-up. HIGH: enable the chip
5	IO10	I/O	GPIO10, FSPICS0. When the value of eFuse bit EFUSE_JTAG_SEL_ENABLE is 0, JTAG signals cannot be used. 1, if IO10 is 0, JTAG signals come from chip pins; if IO10 is 1, JTAG signals cannot be used
6	IO9	I/O	GPIO9
7	IO3	I/O	GPIO3,ADC1_CH3
8	IO4	I/O	GPIO4,ADC1_CH4,FSPIHD,MTMS
9	IO5	I/O	GPIO5,ADC2_CH0,FSPIWP,MTDI
10	IO6	I/O	GPIO6,FSPICLK,MTCK
11	IO7	I/O	GPIO7,FSPID,MTDO
12	GND	P	POWER GND
13	POWER	P	POWER IN, 3.3V
14	IO8	I/O	GPIO8, Internal pull-up
15	RX0	I/O	GPIO20,U0RXD
16	TX0	I/O	GPIO21,U0TXD
17	IO19	I/O	GPIO19,USB-D+
18	IO18	I/O	GPIO18,USB-D-
19	GND	P	Power
22	TX0	I/O	GPIO21,U0TXD

3. Size and Layout

Size for ESPC3-05 can be shown as follows.

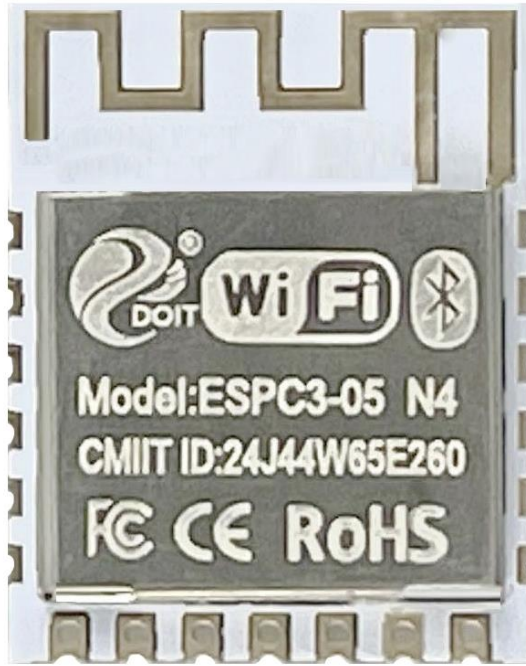
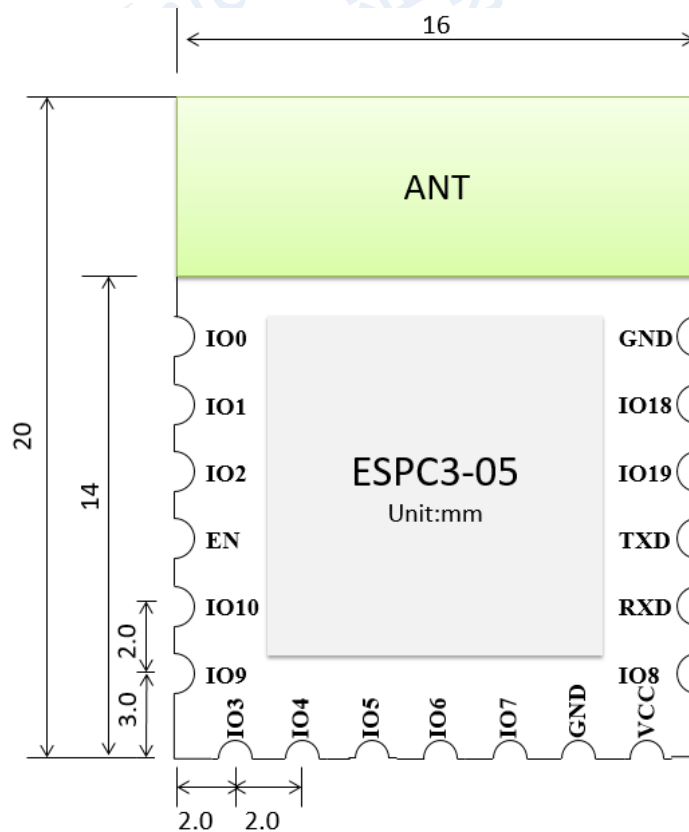

Fig.3.1 Shape for ESPC3-05



(a) Vertical View



Fig.3.2 Size for ESPC3-05

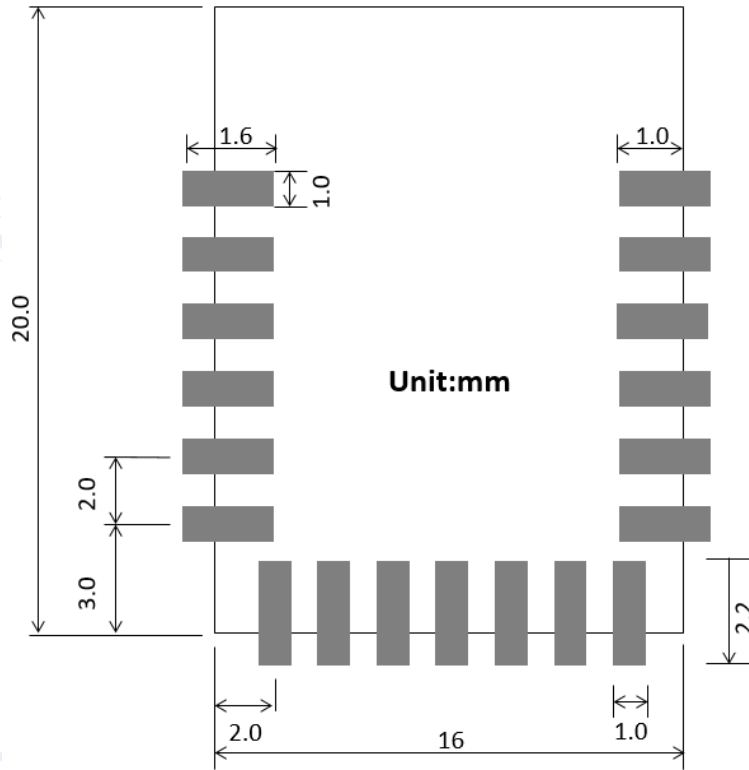

Fig. 3.3 PCB Layout for ESPC3-05

4. Electronica Characteristics

Table.4.1 Electronica Characteristics

Parameter	Condition	Min	Classical	Max	Unit
Store Temperature	-	-40	Normal	150	°C
Sold Temperature	IPC/JEDEC J-STD-020	-	-	260	°C
Working Voltage	-	3.0	3.3	3.6	V
I/O	V _{IL}	-0.3	-	0.25*VDD	V
	V _{IH}	0.75*VDD	-	VDD+0.3	
	V _{OL}	-	-	0.1*VDD	
	V _{OH}	0.8*VDD	-	-	
Electrostatic Release Quantity (Human model)	T _{AMB} =25°C	-	-	2	KV
Electrostatic Release Quantity (Machine model)	T _{AMB} =25°C	-	-	0.5	KV

5. Power Consumption

Table.5.1 Power Consumption

Parameter	Min	Classical	Max	Unit
RX 11b /g/n, HT20	-	-	82	mA
RX 11n, HT40	-	-	84	mA
TX 11b, 1Mbps @21dBm	-	-	350	mA
TX 11g, 54Mbps @19dBm	-	-	295	mA
TX 11n, HT20, MCS7, @18.5dBm	-	-	290	mA
TX 11n, HT40, MCS7, @18.5dBm	-	-	290	mA
Modem-sleep, CPU is powered on @80MHz	-	15	-	mA
Light-sleep	-	130	-	uA
Deep-sleep, RTC timer + RTC memory	-	5	-	uA
Power off, CHIP_PU is set to low level	-	1	0	uA

The peak current consumption of ESPC3-05 exceed 400mA when the module start work (RF calibration work consumes maximum current). Therefore, the recommended power supply is no less than 500mA.

Note:

1. Active Mode: CPU and RF are all turned on.
2. Modem-sleep Mode: CPU is turned on. RF and baseband are turned off, but the communication is still connected.
3. Light-sleep Mode: CPU is turned off. RTC/external interrupt/MAC can wake up the chip. The communication is still connected.
4. Deep-sleep Mode: Only RTC is turned on.

6. Wi-Fi RF Characteristics

The data in the following table is gotten when voltage is 3.3V in the indoor temperature environment.

Table.6.1 Wi-Fi TX Characteristics

Parameter	Min	Classical	Max	Unit
Input frequency	2412	-	2484	MHz

802.11b @1Mbps,11Mbps	-	20.5	-	dBm
802.11g @6Mbps	-	20.0	-	dBm
802.11g @54Mbps	-	18.0	-	dBm
802.11n,HT20 MCS0	-	19.0	-	dBm
802.11n,HT40 MCS0	-	18.5	-	dBm
EVM @11b,1Mbps@20dBm	-	-24.5	-	dBm
EVM @11g,54Mbps@19dBm	-	-28	-	dBm
EVM @11n,MCS7@18.5dBm	-	-30	-	dBm
EVM @11n, HT40, MCS7@18.5dBm	-	-30.5	-	dBm

Table.6.2 Wi-Fi RX Sensitivity

Parameter	Min	Classical	Max	Unit
802.11b,1Mbps	-	-98	-	dBm
802.11b,11Mbps	-	-88	-	dBm
802.11g,6Mbps	-	-92	-	dBm
802.11g,54Mbps	-	-76	-	dBm
802.11n,HT20,MCS0	-	-92	-	dBm
802.11n,HT20,MCS3	-	-85	-	dBm
802.11n,HT20,MCS7	-	-74	-	dBm
802.11n,HT40,MCS0	-	-90	-	dBm
802.11n,HT40,MCS3	-	-81	-	dBm
802.11n,HT40,MCS7	-	-71	-	dBm

Table.6.3 Wi-Fi RX Characteristics

Parameter	Min	Classical	Max	Unit
MAX RX Level @11b,1Mbps	-	5	-	dBm
MAX RX Level @11b,11Mbps	-	5	-	dBm
MAX RX Level @11g,6Mbps	-	5	-	dBm
MAX RX Level @11g,54Mbps	-	0	-	dBm
MAX RX Level @11n,HT20,MCS0	-	5	-	dBm
MAX RX Level @11n,HT20,MCS7	-	0	-	dBm

MAX RX Level @11n,HT40,MCS0	-	5	-	dBm
MAX RX Level @11n,HT40,MCS7	-	0	-	dBm
RX Adjacent Channel Rejection@11b,1Mbps	-	35	-	dB
RX Adjacent Channel Rejection@11b,11Mbps	-	35	-	dB
RX Adjacent Channel Rejection@11g,6Mbps	-	31	-	dB
RX Adjacent Channel Rejection@11g,54Mbps	-	14	-	dB
RX Adjacent Channel Rejection@11n,HT20,MCS0	-	31	-	dB
RX Adjacent Channel Rejection@11n,HT20,MCS7	-	13	-	dB
RX Adjacent Channel Rejection@11n,HT40,MCS0	-	19	-	dB

7. Bluetooth LE Radio

Table.7.1 TX Transmitter General Characteristics

Parameter	Min	Classical	Max	Unit
Gain control power	-	3	-	dBm
RF power control range	-27	-	18	dBm
In-band emissions @F-F0±3MHz, LE 1M	-	-41.95	-	dBm
In-band emissions @F-F0±>3MHz, LE 1M	-	-44.48	-	dBm
Modulation characteristics @ Δf1avg, LE 1M	-	245	-	kHz
Modulation characteristics @Δf2max, LE 1M	-	208	-	kHz
Carrier frequency offset, LE 1M	-	-9	-	kHz
In-band emissions @F-F0±5MHz, LE 2M	-	-45.26	-	dBm
In-band emissions @F-F0±>5MHz, LE 2M	-	-47	-	dBm
Modulation characteristics @ Δf1avg, LE 2M	-	497	-	kHz
Modulation characteristics @Δf2max, LE 2M	-	398	-	kHz
Carrier frequency offset, LE 2M	-	-9	-	kHz
In-band emissions @F-F0±3MHz, LE 500K	-	-41.3	-	dBm
In-band emissions @F-F0±>3MHz, LE 500K	-	-42.8	-	dBm
Modulation characteristics @ Δf1avg, LE 500K	-	220	-	kHz
Modulation characteristics @Δf2max, LE 500K	-	205	-	kHz
Carrier frequency offset, LE 500K	-	-11.9	-	kHz

Maximum received signal @30.8% PER	-	10	-	dBm
------------------------------------	---	----	---	-----

Table.7.2 RX Transmitter General Characteristics

Parameter		Min	Classical	Max	Unit
1 M	Sensitivity @30.8% PER	-	-96	-	dBm
	Maximum received signal @30.8% PER	-	10	-	dBm
	Co-channel C/I	-	8	-	dB
	Image frequency	-	-29	-	dB
	Adjacent channel to image frequency @F =F _{image} +1	-	-38	-	dB
	Adjacent channel to image frequency @F =F _{image} -1	-	-34	-	dB
	Adjacent channel selectivity @ F =F0+1	-	-4	-	dB
	Adjacent channel selectivity @ F =F0-1	-	-3	-	dB
	Adjacent channel selectivity @ F ≥F0+3	-	-	-	dB
	Adjacent channel selectivity @ F ≤F0-3	-	-39	-	dB
2 M	Sensitivity @30.8% PER	-	-93	-	dBm
	Maximum received signal @30.8% PER	-	0	-	dBm
	Co-channel C/I	-	10	-	dB
	Image frequency	-	-27	-	dB
	Adjacent channel to image frequency @F =F _{image} +2	-	-39	-	dB
	Adjacent channel to image frequency @F =F _{image} -2	-	-	-	dB
	Adjacent channel selectivity @ F =F0+2	-	-7	-	dB
	Adjacent channel selectivity @ F =F0-2	-	-7	-	dB
	Adjacent channel selectivity @ F ≥F0+6	-	-39	-	dB
	Adjacent channel selectivity @ F ≤F0-6	-	-39	-	dB
1 2 5 K	Sensitivity @30.8% PER	-	-104	-	dBm
	Maximum received signal @30.8% PER	-	10	-	dBm
	Co-channel C/I	-	2	-	dB
	Image frequency	-	-34	-	dB
	Adjacent channel to image frequency @F =F _{image} +1	-	-44	-	dB
	Adjacent channel to image frequency @F =F _{image} -1	-	-37	-	dB
	Adjacent channel selectivity @ F =F0+2	-	-40	-	dB

Adjacent channel selectivity @ $F = F0-2$	-	-42	-	dB
Adjacent channel selectivity @ $F \geq F0+3$	-	-	-	dB
Adjacent channel selectivity @ $F \leq F0-3$	-	-46	-	dB

8. Recommended Solder Temperature Curve

- (1) Reflow Times ≤ 2 times (Max.)
- (2) Max Rising Slope: $3^{\circ}\text{C}/\text{sec}$
- (3) Max Falling Slope: $-3^{\circ}\text{C}/\text{sec}$
- (4) Over 217°C Time: 60~120sec
- (5) Peak Temp: $240^{\circ}\text{C} \sim 250^{\circ}\text{C}$

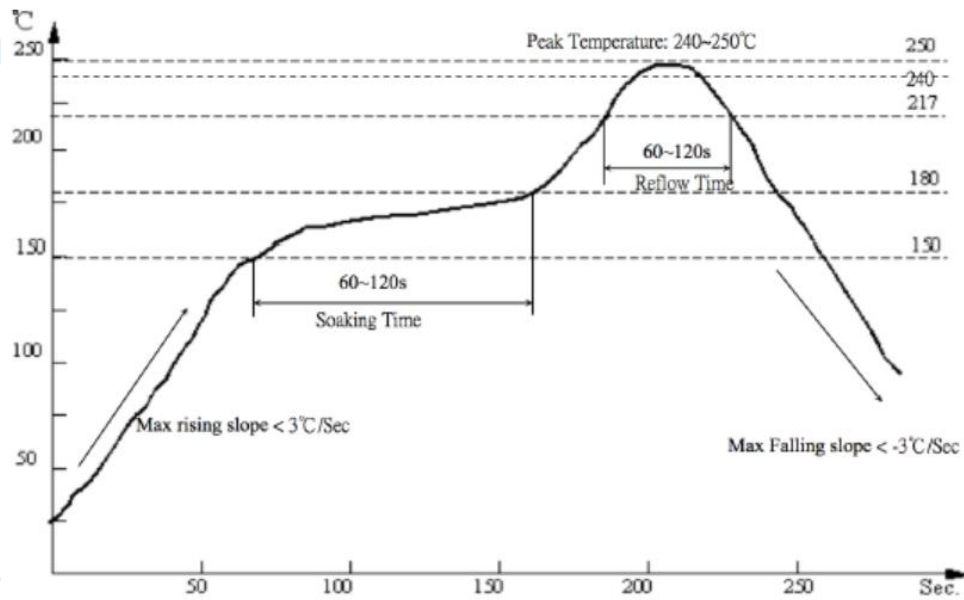

Fig.8.1 Recommended Reflow Profile

9. Minimum User System

This module can work just at 3.3V voltage condition:

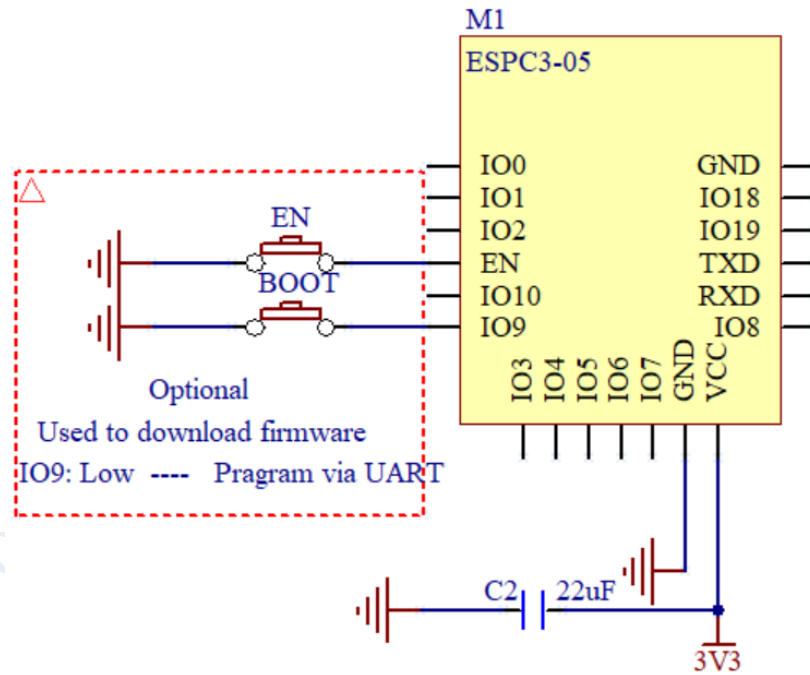

Fig.9.1 Minimum System

Note:

- (1) The working voltage for module is DC 3.3V;
- (2) The max current from IO of this module is 40mA;
- (3) Wi-Fi module is at download mode: IO9 is LOW level, then module reset to power;
- (4) Wi-Fi module is connected to RXD of the other MCU, and TXD is connected to RXD of the other MCU.

10. Recommended Layout Design

ESPC3-05 module can be sold on PCB board directly. For the high RF performance for the device, please notice the placement of the module. There are three ways to use the module for Wi-Fi Module with PCB antenna.

Solution 1: optical solution. The Wi-Fi module is placed on the side of the board, and the antennas are all exposed, and there is no metal material around the antenna, including wires, metal casings, weight plates, and the like.

Solution 2: sub-optical solution. The Wi-Fi module is placed on the side of the board, and the antenna below is hollowed out. There is a gap of not less than 5 mm reserved with the PCB, and there is no metal material around the antenna, including wires, metal casings, weight plates, and the like.

Solution 3: The Wi-Fi module is placed on the side of the board, and the PCB area under the antenna is empty, and copper cannot be laid.

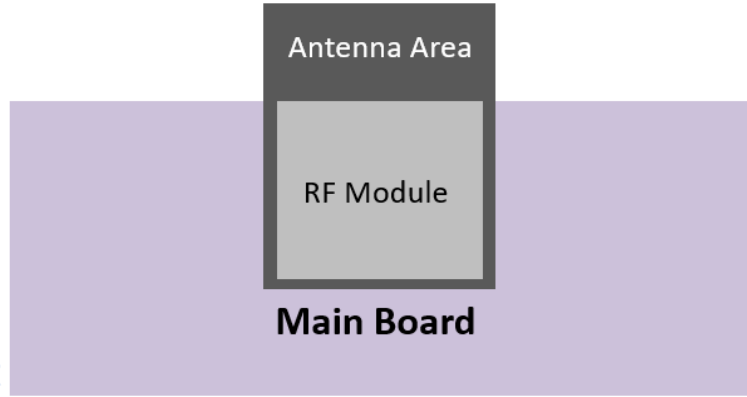

Fig.10.1 Solution 1

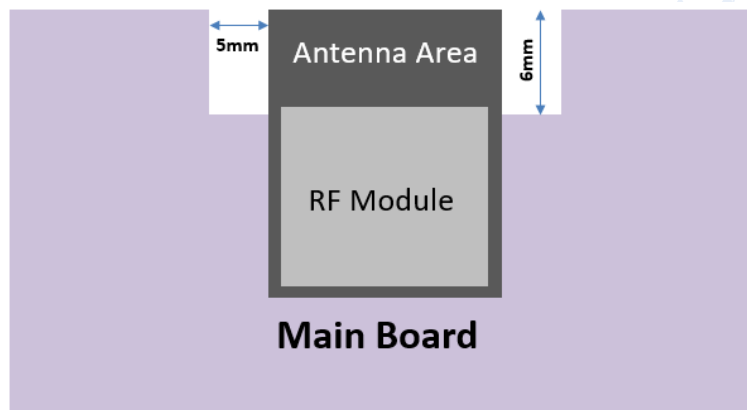

Fig.10.2 Solution 2

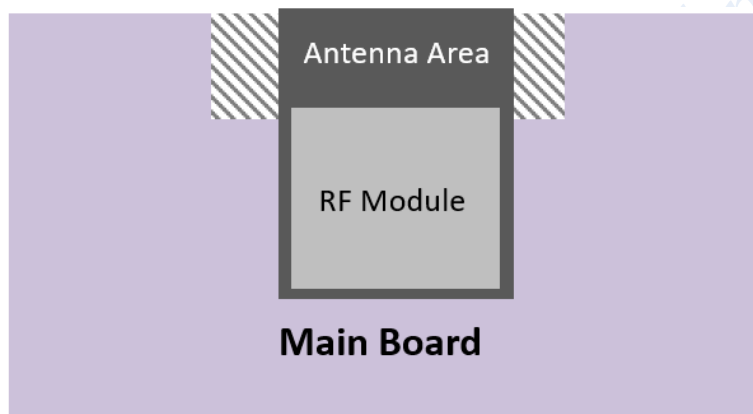

Fig.10.3 Solution 3

11. Peripheral Design Suggestion

Wi-Fi module is already integrated into high-speed GPIO and Peripheral interface, which may be generated the switch noise. If there is a high request for the power consumption and EMI characteristics,

it is suggested to connect a serial 10~100 ohm resistance, which can suppress overshoot when switching power supply, and can smooth signal. At the same time, it also can prevent electrostatic discharge (ESD).

12. Product Handling

12.1 Storage Conditions

The products sealed in moisture barrier bags (MBB) should be stored in a non-condensing atmospheric environment of $< 40\text{ }^{\circ}\text{C}$ and 90%RH. The module is rated at the moisture sensitivity level (MSL) of 3. After unpacking, the module must be soldered within 168 hours with the factory conditions $25\pm 5\text{ }^{\circ}\text{C}$ and 60%RH. If the above conditions are not met, the module needs to be baked.

12.2 Electrostatic Discharge (ESD)

- Human body model (HBM): $\pm 2000\text{ V}$
- Charged-device model (CDM): $\pm 500\text{ V}$

13. Packing Instruction

The product is packed in a tray, as shown in the following figure.

The size of the single box is: 340 x 360 x 60mm, and 1000 pieces module is in the box. And the outer box size is 355 x 375 x 325mm, including 5 single box which include 5000 pieces module.



Fig.13.1 Module Package

14. Module Schematic

