

Product Specification

ESPC2-01E

—2.4GHz Wi-Fi and BLE5.0 Coexistence Module

Version: 1.0

Date: July.20, 2022

Features

General

- Chip: ESP32-C2, ESP8684H2
- Module Size: 14.5mm*24.5mm
- 2MByte embedded flash
- 576KB ROM
- 272KB SRAM

Wi-Fi Features

- IEEE 802.11 b/g/n-compliant
- Center frequency range of operating channel: 2412 ~ 2484 MHz
- Supports 20 MHz bandwidth in 2.4 GHz band
- 1T1R mode with data rate up to 72.2 Mbps
- TX/RX A-MPDU, TX/RX A-MSDU
- Immediate Block ACK
- Fragmentation and defragmentation
- Automatic Beacon monitoring (hardware TSF)
- 3 x virtual Wi-Fi interfaces
- Simultaneous support for Infrastructure BSS in Station mode, Soft-AP mode, Station + Soft-AP mode, and promiscuous mode

Bluetooth Features

- Bluetooth LE: Bluetooth 5
- Speed: 125 Kbps, 500 Kbps, 1 Mbps, 2 Mbps
- Advertising extensions
- Multiple advertisement sets
- Channel selection algorithm #2

Peripheral Interfaces

- GPIO * 5;
- UART;
- IIC ;

- SPI;
- EN ;
- PWM;
- ADC;

Working Temperature: -40°C-105°C

Applications

- Serial transparent transmission;
- Wi-Fi prober;
- Smart power plug/Smart LED light;
- Mesh networks;
- Sensor networks;
- Over-the-top (OTT) devices;
- Wireless location system beacon;
- Industrial field bus;

Module Type

Name	Antenna Type
ESPC2-01E	U.FL IPEX

Module Structure

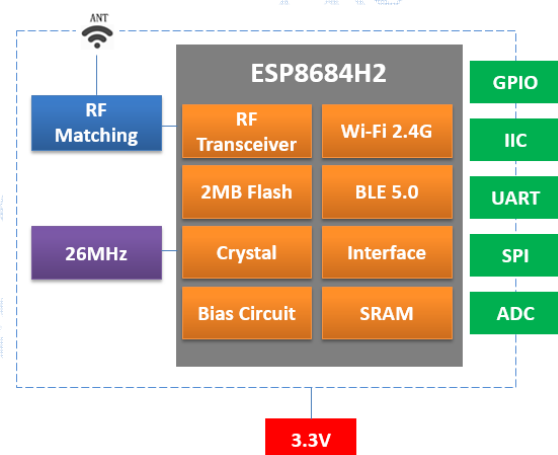

Update Record

Date	Version	Update
2022-07-20	V1.0	First released

Table of Contents

1. Introduction	1
2. Interface Definition	3
3. Size and Layout.....	4
4. Electronica Characteristics.....	4
5. Power Consumption	5
6. Wi-Fi RF Characteristics.....	5
7. Bluetooth LE Radio.....	7
8. Minimum User System.....	9
9. Recommended Layout Design	9
10. Peripheral Design Suggestion	9
11. Product Handling.....	10
12. U.F.L RF Connector.....	10
13. Module Schematic.....	11

1. Introduction

ESPC2-01E Wi-Fi and BLE coexistence Module is a highly integrated single-chip low power 802.11bgn Wireless LAN (WLAN) network controller. It combines a RISC CPU, WLAN MAC, a 1T1R capable WLAN baseband, RF, and Bluetooth in a single chip. It also provides a bunch of configurable GPIO, which are configured as digital peripherals for different applications and control usage.

ESPC2-01E Module use ESP8684 as Wi-Fi and BLE coexistence SOC chip.

ESPC2-01E Module integrates internal memories for complete Wi-Fi protocol functions. The embedded memory configuration also provides convenient application developments.

ESPC2-01E module supports the standard IEEE802.11 b/g/n/e/i protocol and the complete TCP/IP protocol stack. User can use it to add the Wi-Fi function for the installed devices, and also can be viewed as an independent network controller. Anyway, ESPC2-01E Wi-Fi module provides many probabilities with the best price.

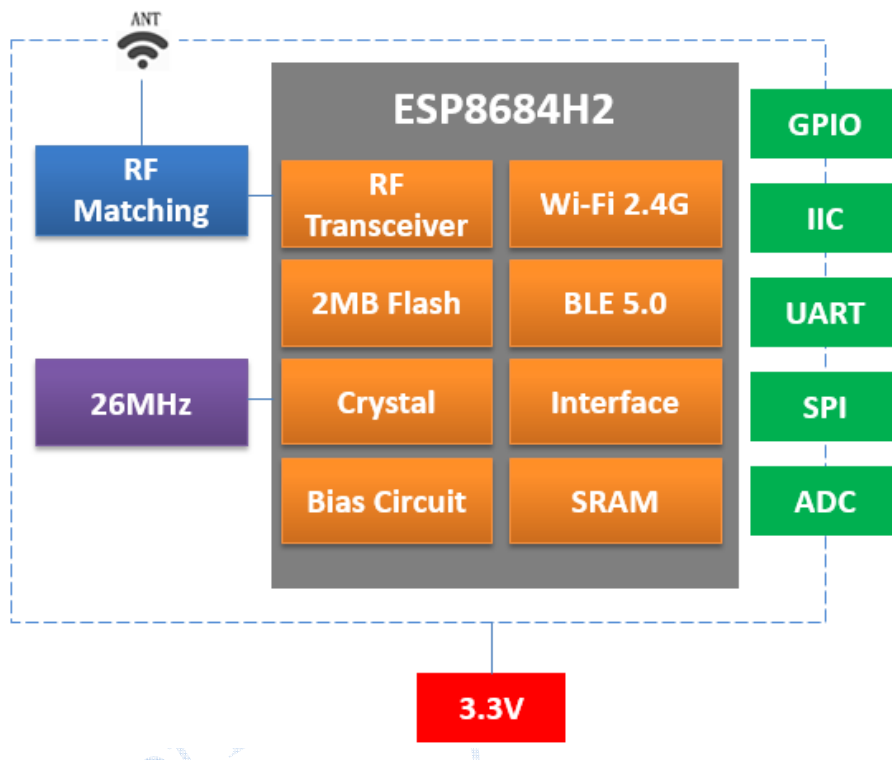

Fig.1.1 ESPC2-01E Module Structure

Technical parameters for ESPC2-01E are listed as follows.

Table.1.1 ESPC2-01E Parameters

Type	Item	Parameter
Wi-Fi	Frequency	2.4G~2.5G (2412M~2484M)
	Transmit power	802.11b: +20.5 dBm
		802.11g: +19 dBm
		802.11n: +18 dBm
	Receiver sensitivity	802.11b: -90 dBm (11Mbps)
		802.11g: -77 dBm (54Mbps)
		802.11n: -74 dBm (MCS7)
	EVM	-25dB @802.11b,11Mbps @21dBm
-27dB @802.11n,54Mbps @19dBm		
-29dB @802.11n,HT20,MCS7 @18.5dBm		
Antenna	PCB antenna	
BLE	RF power control range	-27~20dBm
Hardware	CPU	32-bit RISC CPU
	Interface	UART/SDIO/SPI/I2C/GPIO/PWM
	Working voltage	3.0V ~ 3.6V
	Working temperature	-40°C ~ 105°C
	Environment temperature	-40°C ~ 105°C
	Shape	14.5mm x 24.5mm
Software	Wi-Fi working mode	STA, Soft-AP and sniffer modes
	Security mode	WPS / WEP / WPA / WPA2 / WPA3
	Update firmware	UART Download
	Software develop	SDK
	Network protocol	IPv4, TCP/UDP/HTTP/FTP/MQTT

2. Interface Definition

ESPC2-01E Wi-Fi & BLE module interface definition is shown as below.

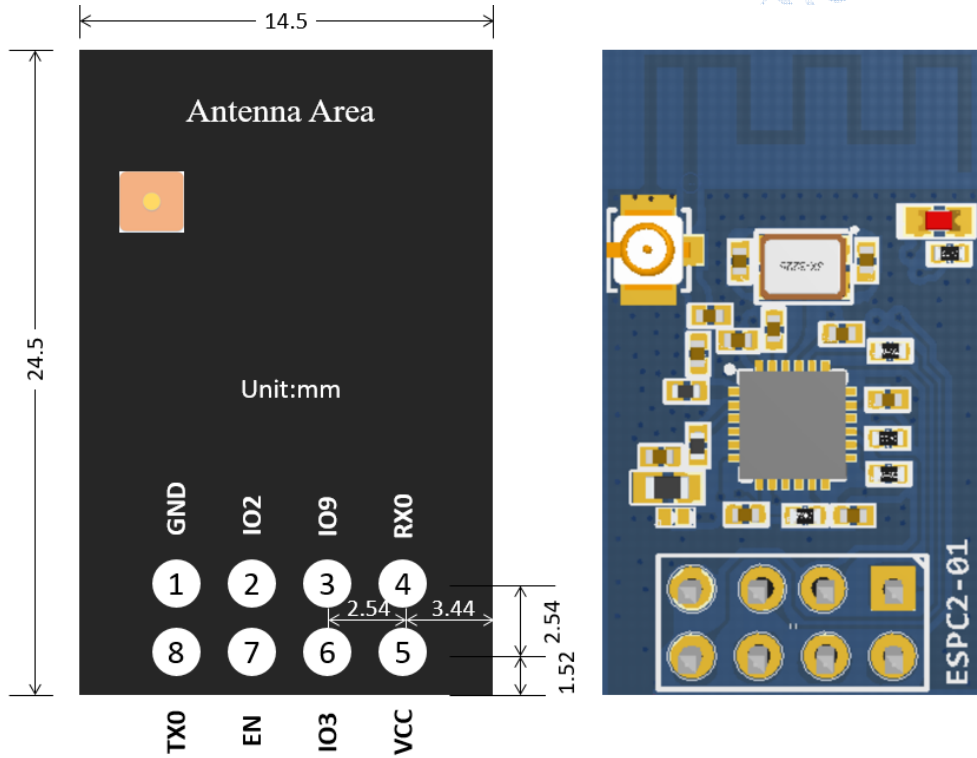

Fig.2.1 ESPC2-01E Pins Definition

Working modes and pins function is shown in Table 2.1.

Table.2.1 Working Mode

Mode	BOOT (IO9) Voltage Level
UART Download Mode	LOW
Flash Boot Mode	HIGH (Default)

Table.2.2 Pins Function Definition

Num.	Pin Name	Type	Function
1	GND	P	Power, 3.3V/500mA Recommended
2	IO2	I/O	GPIO2, ADC1_CH2, FSPIQ
3	IO9	I/O	BOOT Pin, GPIO9
4	RX0	I/O	GPIO19
5	VCC	P	Power, 3.3V/500mA Recommended

6	IO3	I/O	GPIO3, ADC1_CH3
7	EN	I/O	Chip enable; Internal Pull-up. HIGH: enable the chip
8	TX0	I/O	GPIO20

3. Size and Layout

Size for ESPC2-01E can be shown as follows.

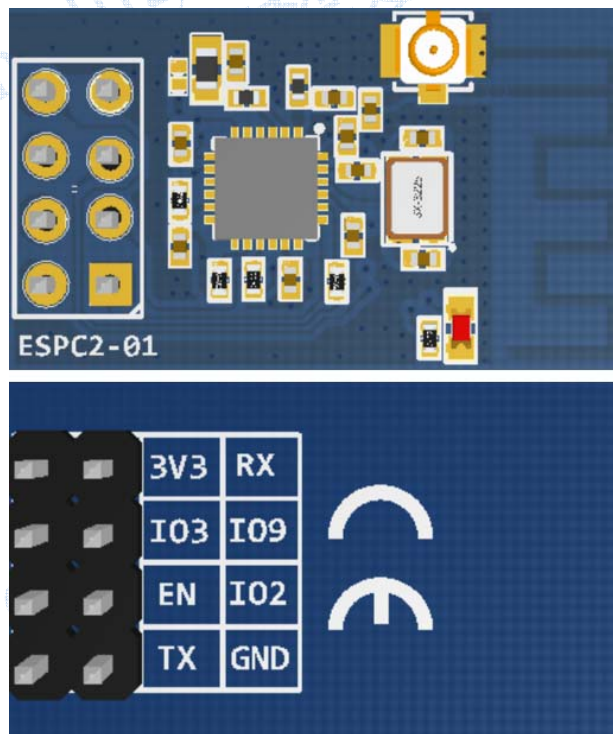

Fig.3.1 Shape for ESPC2-01E

4. Electronica Characteristics

Table.4.1 Electronica Characteristics

Parameters	Condition	Min	Classical	Max	Unit
Store Temperature	-	-40	Normal	150	°C
Sold Temperature	IPC/JEDEC J-STD-020	-	-	260	°C
Working Voltage	-	3.0	3.3	3.6	V
I/O	V _{IL}	-	-0.3	0.25*VDD	V
	V _{IH}	-	0.75*VDD	VDD+0.3	
	V _{OL}	-	-	0.1*VDD	
	V _{OH}	-	0.8*VDD	-	
Electrostatic Release Quantity (Human model)	TAMB=25°C	-	-	2	KV

Electrostatic Release Quantity (Machine model)	TAMB=25°C	-	-	0.5	KV
--	-----------	---	---	-----	----

5. Power Consumption

Table.5.1 Power Consumption

Parameters	Min	Classical	Max	Unit
RX 11b /g/n, HT20	-	-	65	mA
TX 11b, 1Mbps @21dBm	-	-	370	
TX 11g, 54Mbps @19dBm	-	-	320	mA
TX 11n, HT20, MCS7, @18.5dBm	-	-	300	mA
Modem-sleep, CPU is powered on @80MHz	-	15	-	mA
Light-sleep	-	140	-	uA
Deep-sleep, RTC timer + RTC memory	-	5	-	uA
Power off, CHIP_PU is set to low level	-	1	0	uA

The peak current consumption of ESPC2-01E exceed 400mA when the module start work (RF calibration work consumes maximum current). Therefore, the recommended power supply is no less than 500mA.

Note:

1. Active Mode: CPU and RF are all turned on.
2. Modem-sleep Mode: CPU is turned on. RF and baseband are turned off, but the communication is still connected.
3. Light-sleep Mode: CPU is turned off. RTC/external interrupt/MAC can wake up the chip. The communication is still connected.
4. Deep-sleep Mode: Only RTC is turned on.

6. Wi-Fi RF Characteristics

The data in the following table is gotten when voltage is 3.3V in the indoor temperature environment.

Table.6.1 Wi-Fi TX Characteristics

Parameters	Min	Classical	Max	Unit
Input frequency	2412	-	2484	MHz

802.11b @1Mbps,11Mbps	-	20.5	-	dBm
802.11g @6Mbps	-	20.0	-	dBm
802.11g @54Mbps	-	18.0	-	dBm
802.11n,HT20 MCS0	-	19.0	-	dBm
EVM @11b,1Mbps@20dBm	-	-25	-	dBm
EVM @11g,54Mbps@19dBm	-	-26	-	dBm
EVM @11n,MCS7@18.5dBm	-	-29	-	dBm

Table.6.2 Wi-Fi RX Sensitivity

Parameters	Min	Classical	Max	Unit
802.11b,1Mbps	-	-98	-	dBm
802.11b,11Mbps	-	-90	-	dBm
802.11g,6Mbps	-	-92	-	dBm
802.11g,54Mbps	-	-76	-	dBm
802.11n,HT20,MCS0	-	-92	-	dBm
802.11n,HT20,MCS3	-	-85	-	dBm
802.11n,HT20,MCS7	-	-74	-	dBm

Table.6.3 Wi-Fi RX Characteristics

Parameters	Min	Classical	Max	Unit
MAX RX Level @11b,1Mbps	-	5	-	dBm
MAX RX Level @11b,11Mbps	-	5	-	dBm
MAX RX Level @11g,6Mbps	-	5	-	dBm
MAX RX Level @11g,54Mbps	-	0	-	dBm
MAX RX Level @11n,HT20,MCS0	-	5	-	dBm
MAX RX Level @11n,HT20,MCS7	-	-1	-	dBm
RX Adjacent Channel Rejection@11b,1Mbps	-	35	-	dB
RX Adjacent Channel Rejection@11b,11Mbps	-	35	-	dB
RX Adjacent Channel Rejection@11g,6Mbps	-	31	-	dB
RX Adjacent Channel Rejection@11g,54Mbps	-	20	-	dB
RX Adjacent Channel Rejection@11n,HT20,MCS0	-	16	-	dB

RX Adjacent Channel Rejection@1In,HT20,MCS7	-	25	-	dB
---	---	----	---	----

7. Bluetooth LE Radio

Table.7.1 TX Transmitter General Characteristics

Parameters	Min	Classical	Max	Unit
RF power control range	-24	3	20	dBm
In-band emissions @F-F0±3MHz, LE 1M	-	-38	-	dBm
In-band emissions @F-F0±>3MHz, LE 1M	-	-41	-	dBm
Modulation characteristics @ Δf1avg, LE 1M	-	249	-	kHz
Modulation characteristics @Δf2max, LE 1M	-	246	-	kHz
In-band emissions @F-F0±5MHz, LE 2M	-	-43	-	dBm
In-band emissions @F-F0±>5MHz, LE 2M	-	-44	-	dBm
Modulation characteristics @ Δf1avg, LE 2M	-	497	-	kHz
Modulation characteristics @Δf2max, LE 2M	-	589	-	kHz
In-band emissions @F-F0±3MHz, LE 500K	-	-32	-	dBm
In-band emissions @F-F0±>3MHz, LE 500K	-	-38	-	dBm
Modulation characteristics @ Δf1avg, LE 500K	-	273	-	kHz
Modulation characteristics @Δf2max, LE 500K	-	243	-	kHz

Table.7.2 RX Transmitter General Characteristics

Parameters	Min	Classical	Max	Unit	
1 M	Sensitivity @30.8% PER	-	-98	-	dBm
	Maximum received signal @30.8% PER	-	8	-	dBm
	Co-channel C/I	-	8	-	dB
	Image frequency	-	-33	-	dB
	Adjacent channel to image frequency @F =F _{image} +1	-	-32	-	dB
	Adjacent channel to image frequency @F =F _{image} -1	-	-34	-	dB
	Adjacent channel selectivity @ F =F0+1	-	-1	-	dB
	Adjacent channel selectivity @ F =F0-1	-	-3	-	dB
	Adjacent channel selectivity @ F ≥F0+3	-	-33	-	dB
	Adjacent channel selectivity @ F ≤F0-3	-	-31	-	dB

2 M	Sensitivity @30.8% PER	-	-95	-	dBm
	Maximum received signal @30.8% PER	-	8	-	dBm
	Co-channel C/I	-	9	-	dB
	Image frequency	-	-35	-	dB
	Adjacent channel to image frequency @ $F = F_{\text{image}}+2$	-	-35	-	dB
	Adjacent channel to image frequency @ $F = F_{\text{image}}-2$	-	-11	-	dB
	Adjacent channel selectivity @ $F = F_0+2$	-	-11	-	dB
	Adjacent channel selectivity @ $F = F_0-2$	-	-7	-	dB
	Adjacent channel selectivity @ $F \geq F_0+6$	-	-39	-	dB
	Adjacent channel selectivity @ $F \leq F_0-6$	-	-33	-	dB
1 2 5 K	Sensitivity @30.8% PER	-	-106	-	dBm
	Maximum received signal @30.8% PER	-	8	-	dBm
	Co-channel C/I	-	3	-	dB
	Image frequency	-	-41	-	dB
	Adjacent channel to image frequency @ $F = F_{\text{image}}+1$	-	-7	-	dB
	Adjacent channel to image frequency @ $F = F_{\text{image}}-1$	-	-5	-	dB
	Adjacent channel selectivity @ $F = F_0+2$	-	-35	-	dB
	Adjacent channel selectivity @ $F = F_0-2$	-	-34	-	dB
	Adjacent channel selectivity @ $F \geq F_0+3$	-	-41	-	dB
Adjacent channel selectivity @ $F \leq F_0-3$	-	-45	-	dB	

8. Minimum User System

This module can work just at 3.3V voltage condition.

Note:

- (1) The working voltage for module is DC 3.3V;
- (2) The max current from IO of this module is 40mA;
- (3) Wi-Fi module is at download mode: IO9 is LOW level, then module reset to power;
- (4) Wi-Fi module is connected to RXD of the other MCU, and TXD is connected to RXD of the other MCU.

9. Recommended Layout Design

ESPC2-01E module can be sold on PCB board directly. For the high RF performance for the device, please notice the placement of the module. There is a commended way to use the module for Wi-Fi Module with PCB antenna.

Solution: optical solution. The Wi-Fi module is placed on the side of the board, and the antennas are all exposed, and there is no metal material around the antenna, including wires, metal casings, weight plates, and the like.

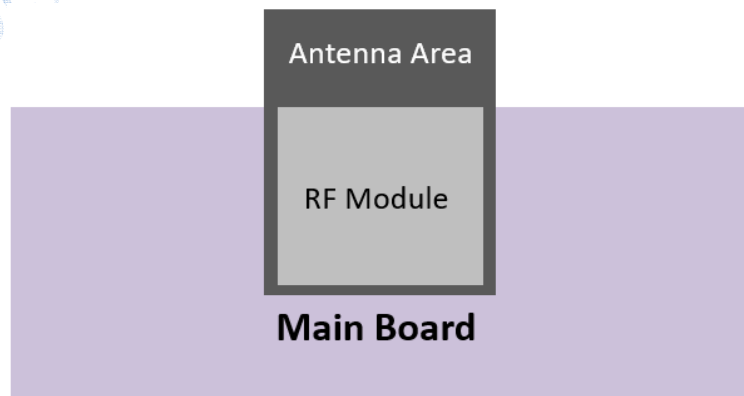

Fig.9.1 Layout Solution

10. Peripheral Design Suggestion

Wi-Fi module is already integrated into high-speed GPIO and Peripheral interface, which may be generated the switch noise. If there is a high request for the power consumption and EMI characteristics, it is suggested to connect a serial 10~100 ohm resistance, which can suppress overshoot when switching power supply, and can smooth signal. At the same time, it also can prevent electrostatic discharge (ESD).

11. Product Handling

11.1 Storage Conditions

The products sealed in moisture barrier bags (MBB) should be stored in a non-condensing atmospheric environment of $< 40\text{ }^{\circ}\text{C}$ and 90%RH. The module is rated at the moisture sensitivity level (MSL) of 3. After unpacking, the module must be soldered within 168 hours with the factory conditions $25\pm 5\text{ }^{\circ}\text{C}$ and 60%RH. If the above conditions are not met, the module needs to be baked.

11.2 Electrostatic Discharge (ESD)

- Human body model (HBM): $\pm 2000\text{ V}$
- Charged-device model (CDM): $\pm 500\text{ V}$

12. U.F.L RF Connector

ESPC2-01E module use U.F.L type RF connector for external antenna connection. (IPEX V1.0).

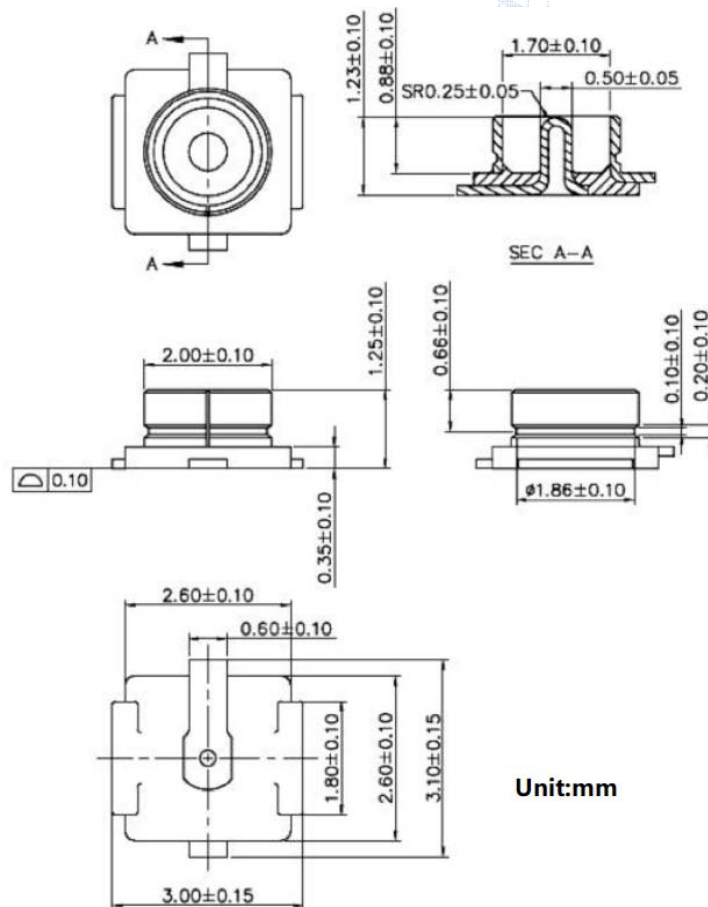
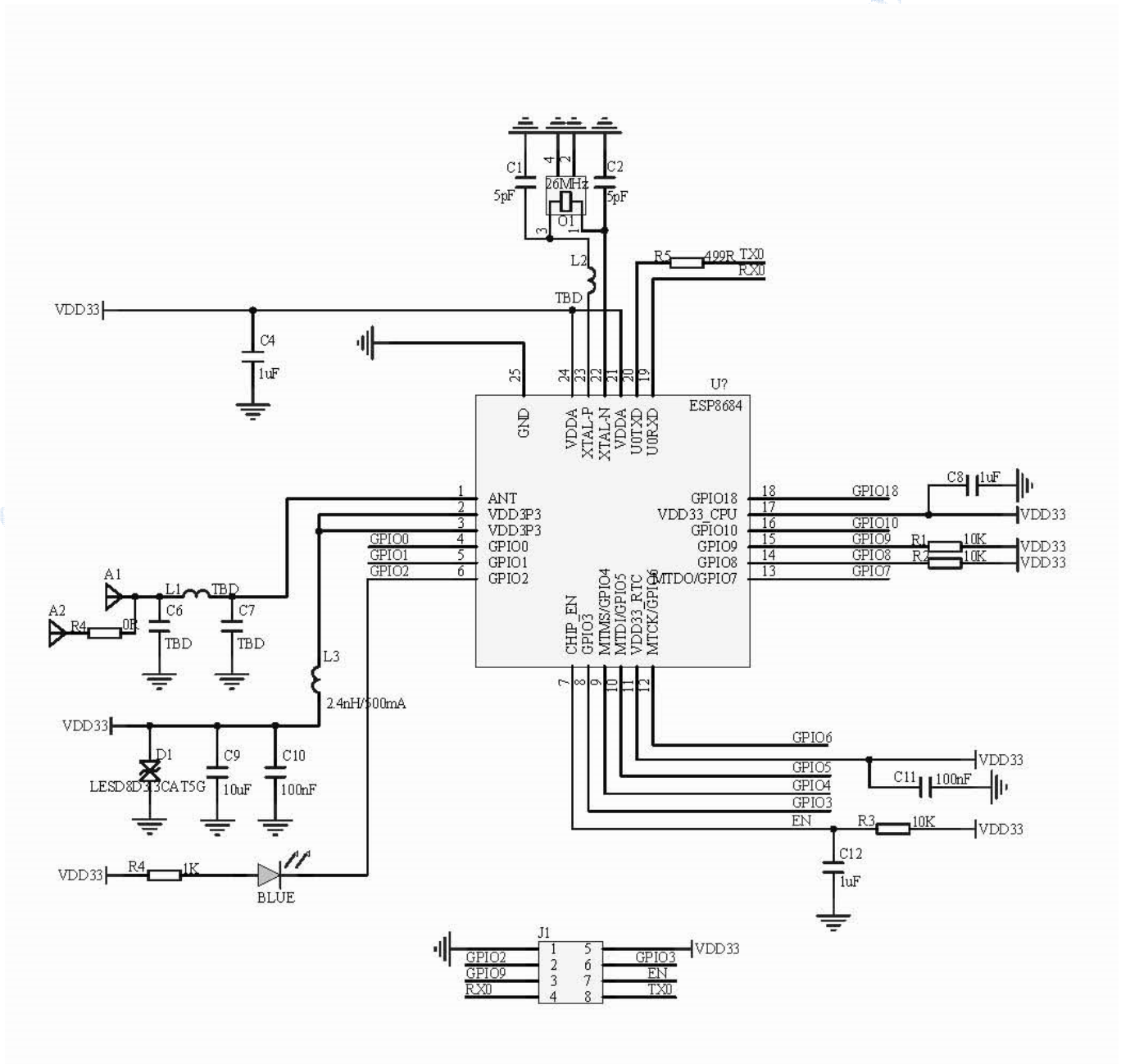

Fig.12.1 U.F.L RF Connector

13. Module Schematic



Doctors of Intelligence & Technology
 严林及